

Complete problems 0–5 and **one** of the last two problems

0. Why is Thèvenin Equivalence the most important/useful concept in this class? Be sure to include three examples of how it was used in class

1. The circuit shown right is driven with a 3 V_{rms} source at 2.5 kHz. Find the magnitude and phase of the current at the location of the ammeter shown in the circuit. Does this current lead or lag the voltage source? Report the voltage across and current through the inductor as would be measured by a DMM.

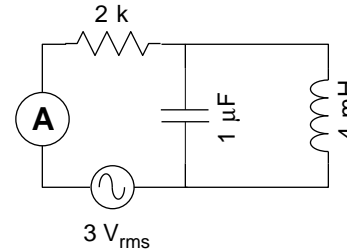

2. Provide a brief definition of the following electronics terms:

- | | |
|----------------------------|---------------------------------|
| (a) current source | (f) biasing |
| (b) short circuit | (g) amplifier $f_{-3\text{dB}}$ |
| (c) output impedance | (h) h_{fe}, r_e |
| (d) stiff (voltage source) | (i) y_{fs}, y_{os} |
| (e) p-type/n-type material | (j) Coupling ► AC (scope) |

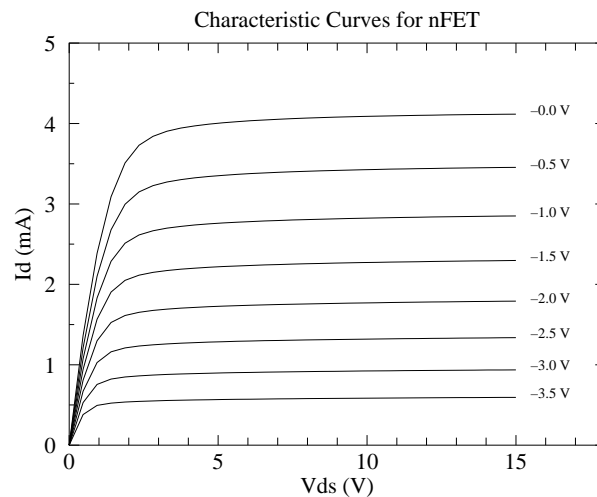

3. Find above the characteristic curves of a FET that is to be used in a common source amplifier with a supply voltage of 16 V. Diagram this circuit showing input and output locations. Draw—directly on the above characteristic curves—the load line for a 4 kΩ drain resistor. Using an operating point with $V_{GS} = -1.5\text{ V}$, what is the quiescent drain current? What is the transconductance at this operating point? How much power is dissipated in the transistor in this quiescent state? One way of biasing the gate to $V_{GS} = -1.5\text{ V}$ is to use a source resistor R_S (bypassed with a capacitor so the ac signal doesn't use it). What value of R_S should you use for your circuit? What value bypass capacitor is required if the amplifier is to operate on audio signals: 20–20,000 Hz. Report the expected voltage gain and both input and output impedance.

4. Build a BJT amplifier with $V_{CC} = 12\text{ V}$, voltage gain of 15, and an output impedance of $4\text{ k}\Omega$. Begin by assuming $\beta = 150$; use a design that has $V_{CE} = \frac{1}{3} V_{CC}$. Report the following DC characteristics: V_E (the emitter voltage), V_C (the collector voltage), V_B (the base voltage), I_E (the emitter current), and the estimated base current I_B . Determine the biasing resistors using either Method 1 (i.e., H&H) or Method 2 (gray-haired codger). Once you have determined your biasing resistors, see how the resulting voltage divider responds to different base currents: calculate V_B if the base current is zero and if the base current is double the estimated base current calculated above. Report the AC input impedance and output impedance assuming the capacitors act as shorts. Assume that the amplifier is to be only used with frequencies above 1 kHz ; Calculate the value of the capacitors C_{in} , C_{out} , C_E .

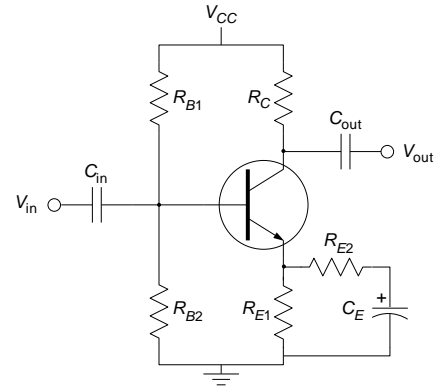

5. Circuit City! Describe briefly what each circuit does. (Feel free to answer directly on this sheet.)

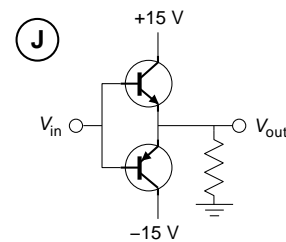
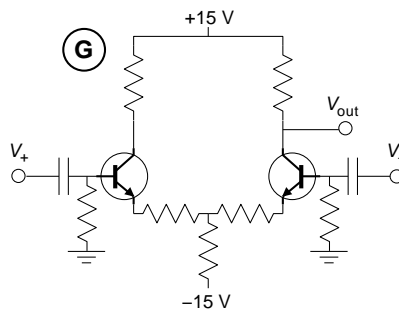
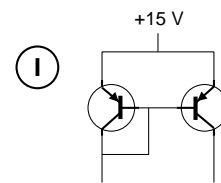
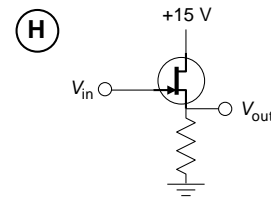
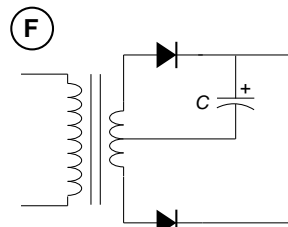
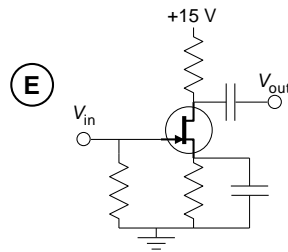
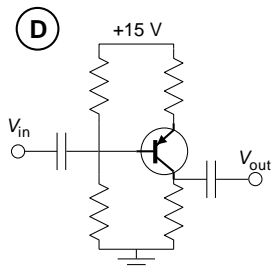
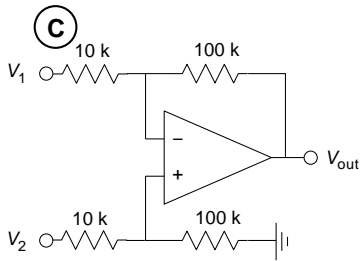
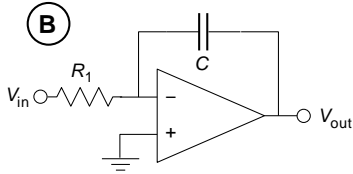
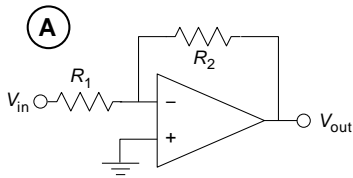

6. You are trying to understand the behavior of a device with two terminals. When you measure the voltage between the two terminals with a digital voltmeter you get 5 V. When you attach a $200\ \Omega$ resistor between the two terminals you measure 4.5 V between the terminals. Calculate component values for a Thévenin equivalent circuit for the device and draw that equivalent circuit. If you attach a $50\ \Omega$ resistor between the terminals, how much power will be dissipated in the resistor?
7. A homework problem describes a series LR circuit that is powered by a source producing a sine wave at $5\ V_{rms}$. Using the problem's component values and frequency a student calculates the current as $I = 5/(R + i\omega L)$ and gets $(12 - 5i)$ mA. Given all the proper components (inductor, resistor, properly adjusted function generator) and the usual measurement tools available in our lab, report how this calculation could be confirmed by direct *measurement*. Display the measurement results; explain how the results correspond to the calculated answer. Use schematics to show exactly how any measurement tools would be attached to the circuit.